

DREHARMATUREN / ROTARY VALVES / VANNES À TOURNANT

Baureihe/Series/Série

Ausführung

Kompakt-Kugelhahn,
handbetätigt

Design

Sandwich-ball valve,
manually operated

Construction

Robinet à boisseau sphérique
compacte, commande pneumatique



KK/F

Modification techniques possibles sans préavis!
Graphique non à l'échelle!
Dimensions valables uniquement revêtues d'une signature!

This leaflet is subject to alteration!
Drawing not to scale!
Certified for construction purposes only when signed!

Technische Änderungen vorbehalten!
Nicht maßstäblich!
Maße nur mit Unterschrift verbindlich!

Maßblatt / dimensional drawing / plan dimensionnel

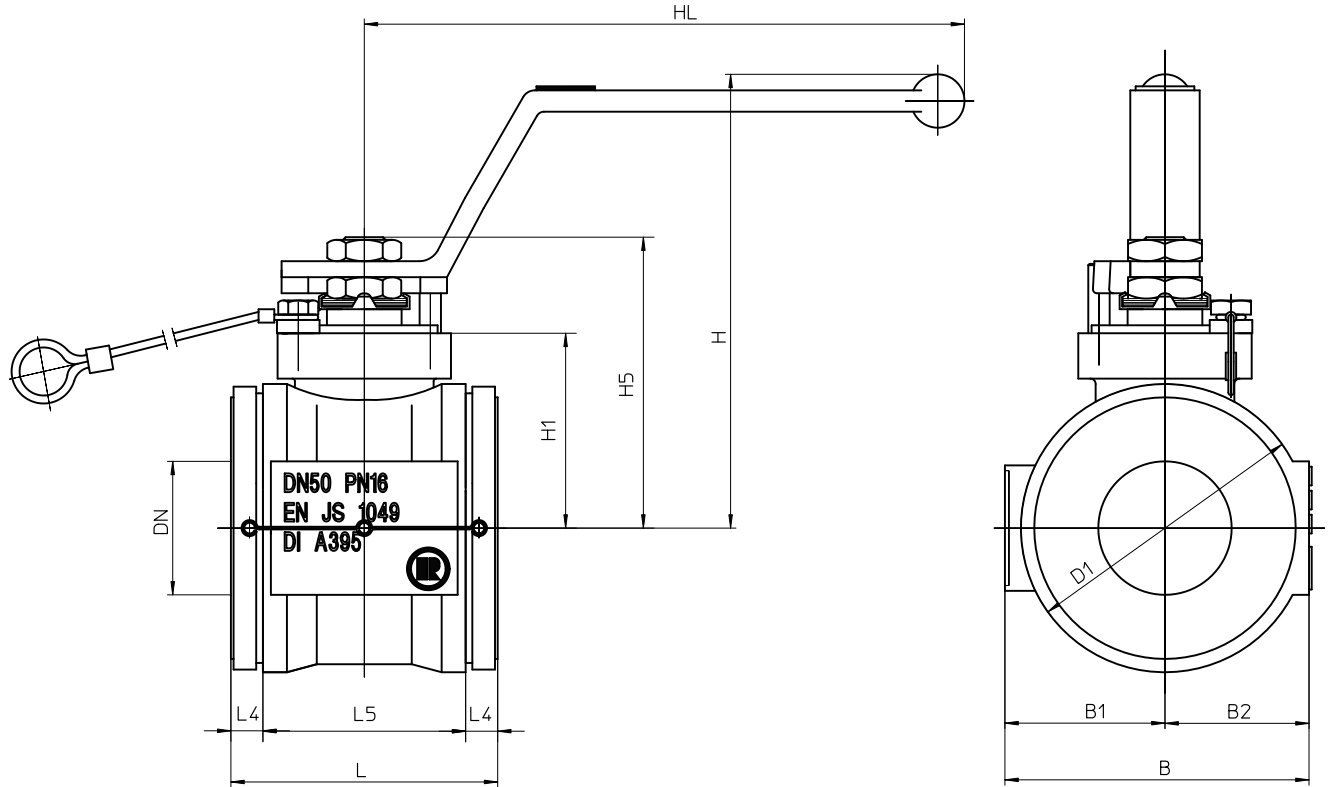

DREHARMATUREN / ROTARY VALVES / VANNES À TOURNANT

Baureihe/Series/Série

Ausführung

**Kompakt-Kugelhahn,
handbetätigt**

Design

**Sandwich-ball valve,
manually operated**

Construction

**Robinet à boisseau sphérique
compacte, commande pneumatique**



KK/F

Modification techniques possibles sans préavis!
 Graphique non à l'échelle!
 Dimensions valables uniquement revêtues d'une signature!

This leaflet is subject to alteration!
 Drawing not to scale!
 Certified for construction purposes only when signed!

Technische Änderungen vorbehalten!
 Nicht maßstäblich!
 Maße nur mit Unterschrift verbindlich!

DN		25 (1")	40 (1.5")	50 (2")	65 (2.5")	80 (3")	100 (4")	150 (6")
H1	mm	44	69	73		105	113	159
	inch	1.73	2.72	2.87		4.13	4.45	6.26
H5	mm	70,5	106	109	111	145,4	160	213
	inch	2.78	4.17	4.29	4.37	5.57	6.30	8.39
H	mm	120	165	170		200	190	233
	inch	4.72	6.50	6.69		7.87	7.48	9.17
HL	mm	150	225				325	400
	inch	5.91	8.86				12.79	15.75
L	mm	75	90	100	115	130	150	200
	inch	2.95	3.54	3.94	4.53	5.12	5.91	7.87
L4	mm	15,5	12		19,5	18	12	44
	inch	0.61	0.47		0.77	0.71	0.47	1.73
L5	mm	44	66	76		94	126	112
	inch	1.73	2.60	2.99		3.70	4.96	4.41
ØD1	mm	69	94	108	124	134	168	220
	inch	2.71	3.70	4.25	4.88	5.27	6.61	8.66
B	mm	77,5	106	115		137	173	224
	inch	3.05	4.17	4.53		5.39	6.81	8.82
B1	mm	41,5	55	60		68	88	112
	inch	1.63	2.17	2.36		2.68	3.46	4.41
B2	mm	36	51	55		69	85	112
	inch	1.41	2.00	2.17		2.72	3.35	4.41
Kugel- Innen-Ø.	mm	24	38	46		65	78	110
	inch	0.94	1.49	1.81		2.56	3.07	4.33