

TOTAL HERMETIX – INTEGRITY PACKAGE

As a standard, most of Habonim valves are equipped with the Total HermetiX™ Integrity Package comprised of three main elements and superior inline sealing mechanisms in some of them:

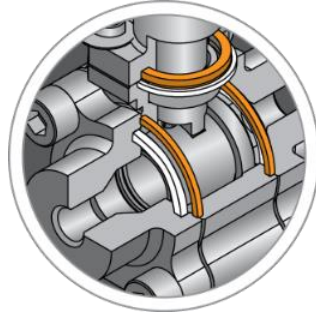

DOUBLE BODY SEALING

- Body-to-ends & body-to-bonnet double sealing for superior atmospheric sealing.
- Selection of sealing materials for diverse applications.
- Fugitive emission prevention.

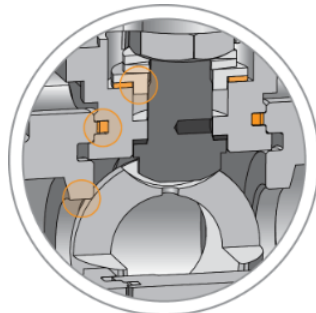

ZERO FUGITIVE-EMISSION NO MAINTENANCE STEM SEALING

- Patented HermetiX™ stem sealing design with zero fugitive emission sealing capability.
- Tested or certified according to ISO 15848-1 and API641 standards.
- Up to 500,000 cycles of operation with no maintenance guaranteed.
- Field proven for millions of cycles continuous operation.

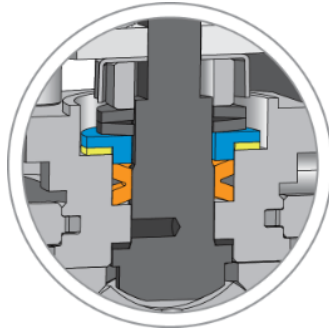

FIRE SAFE

- Tested and certified according to API 607 and ISO 10497.
- Type-tested and certified by leading certification bodies for marine service.
- Clean Fire Safe construction guarantees no graphite contamination of the media flow.